

SC15MLX.2 MBP Compressor R404A/R507 208-230V 60Hz

General

Code number	104L2803
Approvals	UL984
Compressors on pallet	80

Application

Application	MBP					
Frequency	Hz	50			60	
Evaporating temperature	°C	-			-23.3 to 7.2	
Voltage range	V	-			187 - 254	
Max. condensing temperature continuous (short)	°C	-			50 (60)	
Max. winding temperature continuous (short)	°C	-			125 (135)	

Cooling requirements

Frequency	Hz	50			60		
Application		LBP	MBP	HBP	LBP	MBP	HBP
32°C		-	-	-	-	F ₂	-
38°C		-	-	-	-	F ₂	-
43°C		-	-	-	-	-	-
Remarks on application:							

Motor

Motor type	CSR		
LRA (rated after 4 sec. UL984), HST LST	A	30.0	-
Cut in Current, HST LST	A	30.0	-
Resistance, main start winding (25°C)	Ω	2.6	14.0

Design

Displacement	cm ³	15.28
Oil quantity (type)	cm ³	600 (polyolester)
Maximum refrigerant charge	g	1300
Free gas volume in compressor	cm ³	1460
Weight without electrical equipment	kg	14.0

Dimensions

Height	mm	A	219
		B	213
		B1	193
		B2	110
Suction connector	location/I.D. mm angle	C	9.7 37°
	material comment	Copper Rubber plug	
Process connector	location/I.D. mm angle	D	6.5 37°
	material comment	Copper Rubber plug	
Discharge connector	location/I.D. mm angle	E	6.5 37°
	material comment	Copper Rubber plug	
Oil cooler connector	location/I.D. mm angle	F	-
	material comment	-	
Connector tolerance	I.D. mm	±0.09	
Remarks:			

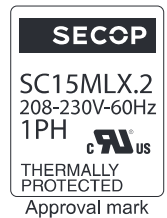
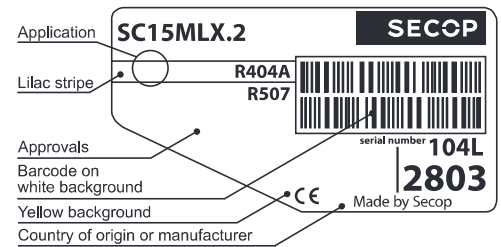

- S = Static cooling normally sufficient
- O = Oil cooling
- F₁ = Fan cooling 1.5 m/s (compressor compartment temperature equal to ambient temperature)
- F₂ = Fan cooling 3.0 m/s necessary
- SG = Suction gas cooling normally sufficient
- = not applicable in this area

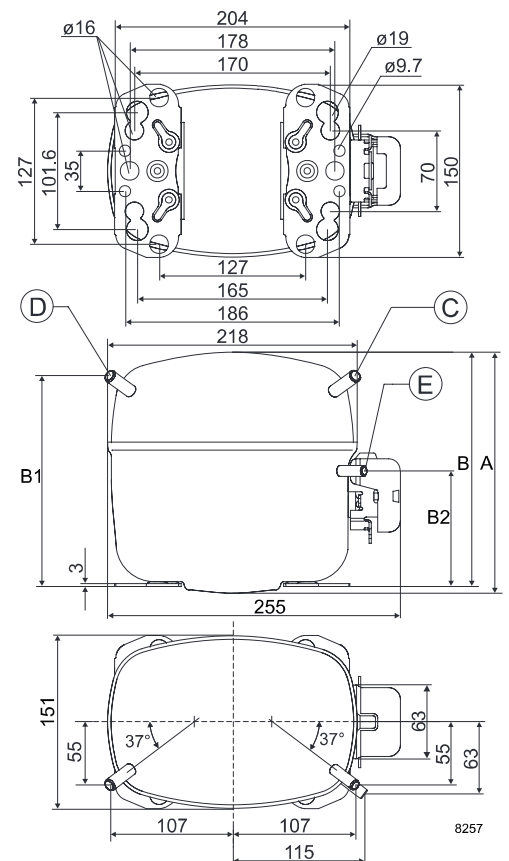

EN 12900 Household (CECOMAF) 230V, 60Hz, fan cooling F₂

Evap. temp. in °C	-45	-40	-35	-30	-25	-23.3	-20	-15	-10	-6.7	-5	0	5	7.2	10	15	20
Capacity in W						784	915	1145	1418	1623	1737	2107	2531	2735			
Power cons. in W						676	722	790	860	907	931	1004	1080	1114			
Current cons. in A						3.09	3.27	3.56	3.88	4.09	4.21	4.55	4.92	5.09			
COP in W/W						1.16	1.27	1.45	1.65	1.79	1.87	2.10	2.34	2.46			

ASHRAE MBP 230V, 60Hz, fan cooling F₂

Evap. temp. in °C	-45	-40	-35	-30	-25	-23.3	-20	-15	-10	-6.7	-5	0	5	7.2	10	15	20
Capacity in W						717	836	1049	1305	1500	1609	1965	2379	2581			
Power cons. in W						703	757	838	920	975	1003	1087	1173	1212			
Current cons. in A						3.22	3.43	3.76	4.11	4.35	4.48	4.87	5.28	5.47			
COP in W/W						1.02	1.11	1.25	1.42	1.54	1.60	1.81	2.03	2.13			

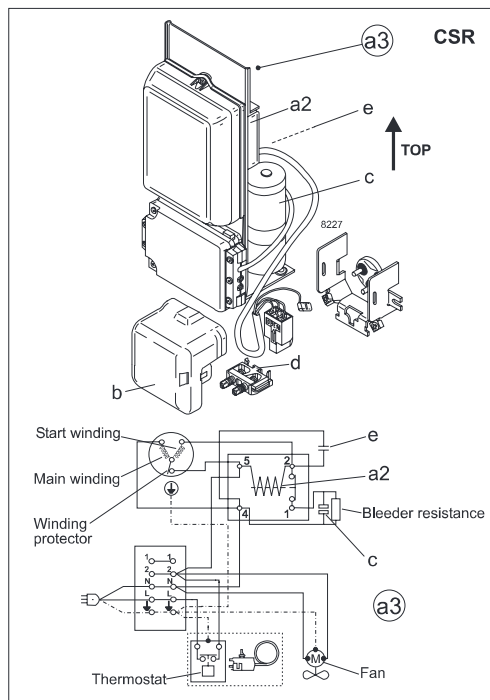

Accessories for	SC15MLX.2	Figure	Code number	Test conditions	EN 12900/ CECOMAF	ASHRAE MBP
Starting device	470 mm cable length	a3	117-7058	Condensing temperature	45°C	54.4°C
Cover		b	103N2008	Ambient temperature	32°C	35°C
Starting relay		a2	Components of starting device	Suction gas temperature	32°C	35°C
Start. capacitor 125 µF		c		Liquid temperature	no subcooling	46.1°C
Run capacitor 15 µF		e		Mounting accessories		
Cord relief		d	103N1004	Bolt joint for one compressor	Ø: 16 mm	118-1917
				Bolt joint in quantities	Ø: 16 mm	118-1918
				Snap-on in quantities	Ø: 16 mm	118-1919

Secop can accept no responsibility for possible errors in catalogues, brochures and other printed material. Secop reserves the right to alter its products without notice. This also applies to products already on order provided that such alterations can be made without consequential changes being necessary in specifications already agreed. All trademarks in this material are property of the respective companies. Secop and the Secop logotype are trademarks of Secop GmbH. All rights reserved. www.secop.com